

# Energy-Efficient Multi-Path Routing in Wireless Sensor Networks

Philipp Hurni and Torsten Braun

Universität Bern, Neubrückestrasse 10, CH-3012 Bern  
hurni|braun@iam.unibe.ch

**Abstract.** The paper investigates the usefulness of multi-path routing to achieve lifetime improvements by load balancing and exploiting cross-layer information in wireless sensor networks. Performance gains in the order of 10-15 % could be achieved by altering path update rules of existing on-demand routing schemes. Problems encountered with concurrent traffic along interfering paths have been identified as a direct consequence of special MAC protocol properties.

**Keywords:** Sensor Networks, Energy Efficiency, Routing Protocols

## 1. Introduction

### 1.1 Benefits of Multi-Path Routing

Standard routing protocols in ad hoc wireless networks, such as AODV [3] and DSR [4] are mainly intended to discover one single route from a source to a destination. During the route discovery process, these protocols aim to find the best route with the lowest cost. Multi-path routing protocols aim to find multiple routes. Multiple routes can be useful to compensate for the dynamic and unpredictable nature of ad hoc networks, also in energy and bandwidth constrained sensor networks. Multi-path routing has been investigated in the Internet, in metropolitan and local area networks, in wireless mobile ad hoc networks, as well as in wireless sensor networks. In [6] goals, problems and recent suggestions for multi-path routing protocols in wireless ad hoc networks have been discussed. Discovering and maintaining multiple paths causes certain overhead, but yields several advantages, namely load balancing, fault tolerance, bandwidth aggregation, and reduced delay [2].

**Load Balancing:** Multi-path routing can avoid congestion and improve performance. When certain nodes and links become over-utilized and cause congestion, multi-path routing can spread traffic over alternate paths to balance the load over those paths. In wireless sensor networks, the main focus of multi-path routing is typically on the load balancing issue. As nodes are constraint to a limited amount of energy, and traffic is expected to be low, the main concern is to keep the network operable for a maximum amount of time. In sensor networks, one has to deal

with traffic generated by many leaf nodes attempting to deliver data to one or a few sinks. Usual on-demand routing schemes tend to utilize always the same set of nodes to forward packets, whereas many other nodes remain unused. It has been observed that in such cases nodes that have to forward traffic from large sub-trees suffer much earlier from energy depletion, whereas other nodes have only slightly been used. When nodes collaborate in sensing and data forwarding and packets are not always routed on the same routes, but the load is balanced over multiple routes, network lifetime can be increased significantly.

**Fault Tolerance:** Multi-path routing protocols can increase the degree of fault tolerance by having redundant information routed to the destination over alternate paths. This increases the energy overhead, but helps to reduce the probability that communication is disrupted and data is lost in case of link failures. Sophisticated algorithms have been developed to increase the degree of reliability. The trade-off between the additional overhead and the reliability gain has been investigated in [5].

**Bandwidth Aggregation:** By splitting data to the same destination into multiple streams, each stream is routed through a different path. The effective bandwidth can be aggregated. This strategy is especially beneficial when a node has multiple low bandwidth links but requires higher bandwidth than each individual link can provide.

**Reduced Delay:** In wireless networks running single path on-demand routing protocols, route failures trigger the path discovery process to find new routes causing route discovery delay. Delay can be reduced in multi-path routing, as backup routes can be identified immediately. Furthermore, discovering several paths and observing Quality-of-Service (QoS) characteristics of both paths permits to switch the load to another route whenever the service parameters of another route promise better quality.

In wireless sensor networks, the focus of multi-path routing is often on load-balancing or fault tolerance, rather than on the aggregation of bandwidth. Often, the goal of multi-path routing protocols is to maximize the time the network is operable and fulfills its observation task.

## 1.2 Route Coupling

Using multiple paths in ad hoc networks to achieve higher bandwidth, balance load or achieve fault tolerance is not as easy as in wired networks. As nodes in the network communicate through the wireless medium, radio interference must be taken into account. Transmissions along one path may interfere with transmissions along another path, even if the paths are link-disjoint or even node-disjoint. The interference may limit the achievable throughput and lead to two paths with impact on each other for forwarding packets. This phenomenon is often referred to as **route coupling**. Route coupling occurs when two routes are located physically close enough to interfere with each other during transmission. As a result, the nodes along those two routes are constantly competing for medium access. The advantages of two routes being available are therefore limited.

Route coupling in wireless networks caused by radio interference between paths can have serious impact on the performance of multi-path routing protocols, even if the paths are disjoint [7]. In some cases, route coupling can even lead to worse results than routing over one single path. The shared transmission medium forces all nodes in

the interference range of a sender to remain silent until completion of a transmission. The problem even gets worse when applying an RTS/CTS scheme. In [9] the influence of route coupling in wireless networks applying multi-path routing has been studied. The following types of routes can be distinguished:

- a) routes with no common collision domain
- b) routes with a common link
- c) routes sharing a common node

Paths of type a) produce the best throughput results, because the common collision domain of the multiple paths is reduced to source and destination nodes, and transmission along the path are independent to the largest possible extent. Although more efficient network utilization due to better load balancing can justify the use of a multi-path routing strategy compared to single path routing, the benefits of multi-path routing in terms of throughput quickly vanish in case of interference [9].

In [10] it is argued that many multi-path routing protocols mainly find routes that are too close to each other to actually behave much different than single path routing schemes. To save energy, multi-path routes must ensure that traffic is routed along routes that do not interfere with each other at all, which is in most cases hard to achieve.

None of the established and well-investigated proposals have considered and incorporated the route-coupling phenomenon for effective load balancing. Recent research has been pursued on the issue of on-demand construction on non-interfering multiple paths in sensor networks [8]. The proposed mechanism routes packets along paths that have a gap of two transmission ranges in between. The mechanism strongly relies on the position-awareness of the sensor nodes and the knowledge of the position of the receiver.

### **1.3 Overview**

This paper investigates the usefulness of multi-path routing in wireless sensor networks. After discussing related work in Section 2, we propose in Section 3 a multi-path routing protocol for wireless sensor networks based on the AODV multi-path extensions called AOMDV. The protocol has been evaluated by simulations as discussed in Section 4. Section 5 concludes the paper.

## **2. Related Work**

### **2.1 Multi-path Routing Protocols**

Several multi-path protocols for wireless ad-hoc networks such as the Ad-hoc On Demand Distance Vector Multi-path routing protocol (AODVM) [14] and Split Multi-path Routing (SMR) [12] have been proposed. The protocol described in this paper has mainly been influenced by the Ad hoc On-demand Multi-path Distance Vector protocol (AOMDV) [13], which is an extension of AODV for discovering node-disjoint or optionally link-disjoint paths. It finds node-disjoint paths by

exploiting a particular property of flooding. By appending the first-hop to the RREQ (Route Request) header, and bookkeeping about the first-hops of the recently received RREQs, nodes receiving duplicate RREQs by different neighboring nodes can easily determine whether the routes are node-disjoint. The first-hop is the first node a RREQ traverses after the initiating source. To find node-disjoint routes, nodes do not immediately reject RREQs. Each RREQ arriving via a different neighbor of the source has a different first-hop in the RREQ header, and therefore defines a node-disjoint path. Nodes do never rebroadcast duplicate RREQs, so any two RREQs arriving at an intermediate node via a different neighbor of the source could not have traversed the same node. As in AODV, RREQ duplicates are discarded in intermediate nodes. RREQs with equal destination sequence number, but incoming from another intermediate node are simply ignored in AODV, unless they advertise a better hop count value. In AOMDV, intermediate and destination nodes reply to such RREQs with RREP (Route Reply) messages, if their first-hop is different from the one in the prior received RREQ. Using this policy, AOMDV guarantees node-disjoint paths whenever it takes up a second routing entry to the same destination. AOMDV further allows discovering link-disjoint paths by exploiting RREQ duplicates arriving at the destination via different intermediate nodes. AOMDV [13] leaves the choice to use the option to the user.

Figure 1 and Figure 2 illustrate the AOMDV mechanisms to find node-disjoint paths. The illustration shows node 1 initiating a route request to node 8. The RREQ is flooded via node 2 and node 3. There, the first-hop field is set accordingly. The RREQs finally reach destination node 8, where both incoming requests create new path entries for source node 1, because the incoming RREQs exhibit a different first-hop. Furthermore, to establish the full bidirectional routes, both RREQs are replied. Node 6 similarly receives two RREQs via nodes 4 and 5. Both RREQs, however, exhibit the same first-hop. Node 6 therefore knows that the paths to the source node advertised by these RREQs are not node-disjoint, and does not add a second path entry. To support multi-path routing, the AOMDV route tables contain a list of intermediate nodes and hop counts for each destination node. The path entries (cf. Table 1 - Table 3) to a destination have all the same destination sequence number, as they have been obtained in one single RREQ-RREP query cycle. When receiving a path advertisement with a higher sequence number, all routes with the old sequence number are removed.

[11] considers how to construct secondary paths, which are in the optimal case node disjoint. The study is focused on the question how to keep the overhead as small as possible if only one node or one link in the network fails. The authors argue that when a small number of paths are kept alive, failures on the primary path can usually be recovered without invoking network-wide flooding for path discovery. This feature is important in sensor networks since flooding is very costly and can vastly reduce network lifetime. Node-disjoint paths are a very strong condition when aiming to find multiple paths between two nodes and may result in rather inefficient and suboptimal paths in terms of hop count. Long detours around many nodes can be necessary to fulfill the condition of node-disjoint paths. Alternate node-disjoint paths can become very long, and therefore require significantly more energy than the primary path. To overcome this problem, and yet retain the robustness advantages of multiple paths, the authors suggest the construction of so-called braided paths. Braided paths relax the

requirement for node-disjoint paths. Such paths are only required to leave out some of the primary path's nodes. They are free to use other nodes on the primary path. In [11] it is proposed to construct two different kinds of redundant paths - node-disjoint paths and braided paths. It depends on the failure patterns which of the two schemes shall be used. It is claimed to achieve better path resilience with the braided path approach.

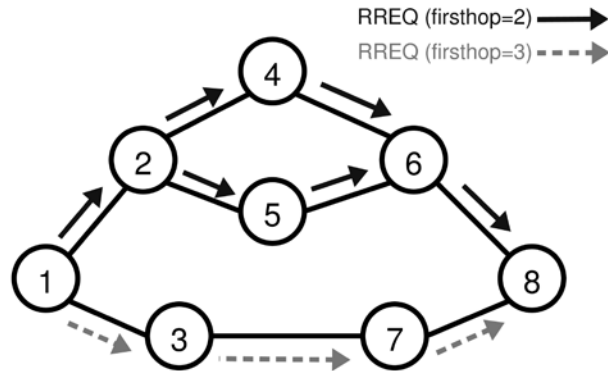

**Figure 1.** AOMDV Route Request

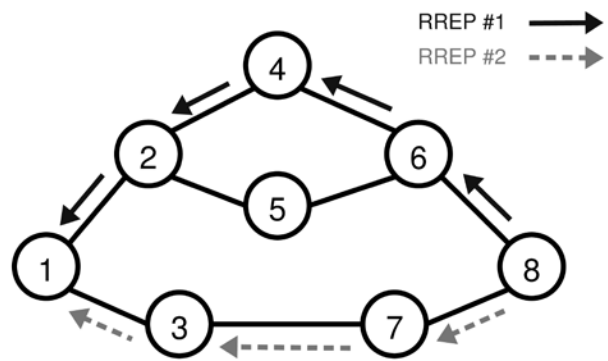

**Figure 2.** AOMDV Route Reply

**Table 1.** Routing table node #1

dest	next	hops	seq
8	3	3	37
8	2	4	37

**Table 2.** Routing table node #6

dest	next	hops	seq
1	4	3	11
8	8	1	37

**Table 3.** Routing table node #8

dest	next	hops	seq
1	7	3	11
1	6	4	11

When discovering and maintaining multiple paths from a source to a destination, it may make sense to occasionally use suboptimal paths in terms of hop count that use more energy for an end-to-end transmission than the optimal one. Traffic load can be spread over multiple paths, which leads to more nodes participating in the forwarding process. Using the lowest energy path for all packets is not necessarily best for the long-term health of a sensor network, as important forwarders might run out of energy first. In [15] a quite simple approach to probabilistically incorporate suboptimal routes is suggested. Each node maintains an energy cost estimate for each of its path entries. This cost estimate determines the probability that a packet is routed over a certain path. If a node aims to transmit a packet to a certain destination for which it has multiple paths, it chooses the forwarding node according to a probability assigned to that path. Each intermediate node does the same and forwards packets according to the probability assigned to the different paths in the table. This is continued until the data packet reaches the destination node. Using this simple mechanism to send traffic over different routes helps in using the nodes' resources more equally. An overall gain of ~40% of network lifetime increase with this probabilistic routing scheme has been achieved. Taking suboptimal paths occasionally into account pays off as nodes use their scarce resources more equally, which helps to remove load from central forwarder nodes that would otherwise run out of energy first.

## 2.2 Sensor MAC Protocols

Routing performance in wireless sensor networks heavily depends on the underlying MAC protocol. Cross-layer designs are required to optimize performance in terms of throughput, energy efficiency, delay etc. WiseMAC [1] appears to be one of the most efficient MAC protocols for wireless sensor networks. It is based on preambles submitted prior to data. If the receiver's wake-up pattern is still unknown, the preambles are slightly longer than the time between two wakeups of a sensor node, such that a sensor node waking up will discover an upcoming transmission from another node and remain active until the frame reception (Figure 3). After successful frame reception, the receiver node piggybacks its own schedule to the respective frame acknowledgement. Received schedule offsets of all neighbor nodes are subsequently kept in a table and are periodically updated. Based on this table, a node can determine the wake-up intervals of all its neighbors and minimize the preamble length for upcoming transmissions.

In previous work we have derived a similar scheme that offers a better protection against systematic overhearing and does not rely on full-cycle preamble for the neighborhood discovery [19]. We propose to implement so-called moving wake periods. Figure 4 shows the approach where a wake period is moving forward and backward within a fixed interval equal to the average time interval between two wakeups of a node in WiseMAC. Nodes just need to select the same fixed interval

value, but do not need to synchronize further. The moving wake periods scheme ensures that two nodes can detect each other by periodic transmission of HELLO messages after a limited time, because their wake periods will sooner or later overlap. If two nodes have detected each other and learned about their schedule they calculate when the other node becomes active again in order to schedule pending transmissions. This scheme proved to avoid overhearing and fairness problems of WiseMAC's fixed static wake-up pattern, in particular when two neighbour nodes share a similar wake pattern. Moving intervals proved to help reducing end-to-end latency over minimum-hop paths by intelligently choosing gateway nodes to forward packets.

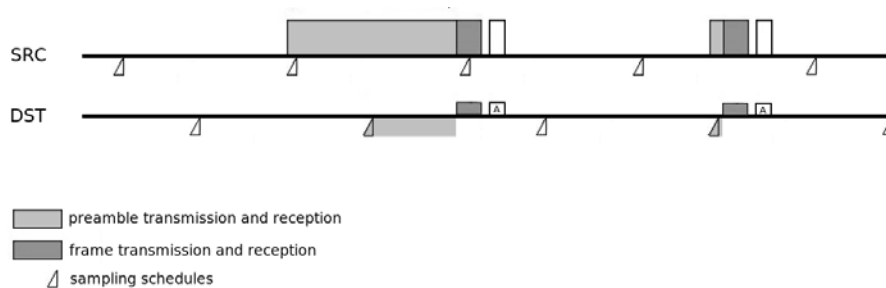

Figure 3. WiseMAC

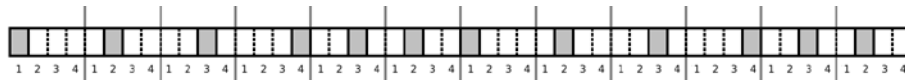

Figure 4. MAC with moving wake periods

### 3. Energy-Efficient Multi-Path Routing for Wireless Sensor Networks

#### 3.1 AOMDV Inspired Multi-path Routing

Our energy-efficient multi-path routing approach is based on AOMDV, because the path construction algorithm of AODVM depends on overhearing neighboring nodes' transmissions. Permanent overhearing requires to keep the receiver constantly in the receive state, which is contrary to the scope of the energy-efficient MAC. Moreover, we found in initial experiments that redundant paths detected by multi-path routing schemes were often much longer than the optimal paths. Long detours of redundant paths have negative impact on the lifetime, because more transmissions become necessary when paths are suboptimal, and each transmission may influence other nodes in the carrier sensing range.

AODV is tailored to the use in mobile ad hoc networks and always keeps the freshest route to every destination. A node receiving a path advertisement for a given destination node checks whether the advertisement provides a higher destination

sequence number, or if it provides an equal destination sequence number and a shorter path to the destination. If it does, the current entry for this destination is deleted and the packet source is taken as new next node towards the destination node. As AODV has been designed for use in mobile ad-hoc networks, in which nodes move in and out of the transmission range of each other, the sequence number condition ensures that a node always uses the path known to be the freshest one. However, most wireless sensor networks can be assumed to be rather static and node mobility does not play a major role. We therefore weakened the condition of prioritizing route advertisements with the highest sequence number. Our approach considers route advertisements to a destination with higher sequence number only, if the route is not longer than the current one. The approach incorporates the basic mechanism of the AOMDV protocol to find node-disjoint paths, but adds such paths only, if they advertise the same hop count. Incoming RREQ duplicates are treated as in AOMDV: they are answered, if they advertise a node-disjoint path to a destination and if they advertise the same hop count. To summarize, we add an additional path entry to the same destination to which a path is already known if it meets all of the following criteria:

- a) the sequence number is equal or higher,
- b) the first-hop is different from all already known paths to the same destination
- c) the hop count is equal.

When a path advertisement arrives with lower hop count, all existing routes are deleted and the new route is added. When receiving a duplicate that fulfils the condition of a node-disjoint path and is optimal in terms of hop count, the routing table is extended to contain more than one path entry. The modification of the routing table entry update rule compared to AOMDV and AODV can be explained by Figure 5, where the dissemination of a RREQ from node 1 searching a path to node 16 is depicted. After flooding the whole network, the destination node receives path advertisements to node 1 from its neighbours 9, 11 and 14. With AODV, the destination node only answers to the first incoming RREQ with a corresponding RREP, e.g., from neighbour 9. The duplicate RREQ from neighbour 11 is simply discarded and left unanswered, as it advertises the same sequence number. Although it took another route and would provide path redundancy, AODV discards the request and leaves it unanswered. In contrast, AOMDV considers all routes that are advertised by neighbours 9, 11 and 14, as the respective RREQs all took another first hop. We changed the table update policy such that only the optimal routes in terms of hop count are added to the table and answered with a RREP. In the previous case, the RREQs received via neighbours 9 and 11 are answered with a RREP, but not the one received via neighbour 14. The resulting routing tables for source node 1 and destination node 16 are depicted in Figure 5. With AODV, only one path entry is considered, whereas AOMDV adds all paths to its table. With our approach, only the hop-count optimal routes via nodes 9 and 11 are added to the table.

AOMDV only addresses the question how to establish multiple routes, but not how to spread the load over them. There are probabilistic schemes that assign a certain probability to a route and choose the route for each packet in a random manner. We suggest exploiting information provided by the MAC layer to achieve some performance gains in respect to the latency. As all redundant path entries to a destination advertise an optimal route in terms of hop count, the next soonest wake-up of the gateway leading to the destination shall be the only selection criterion, also in



each intermediate node. For a transmission of a packet from source to destination, each intermediate node shall forward the packet to the node with the soonest wake-up. A lower latency as well as the desired load balancing among the intermediate nodes can thus be expected.

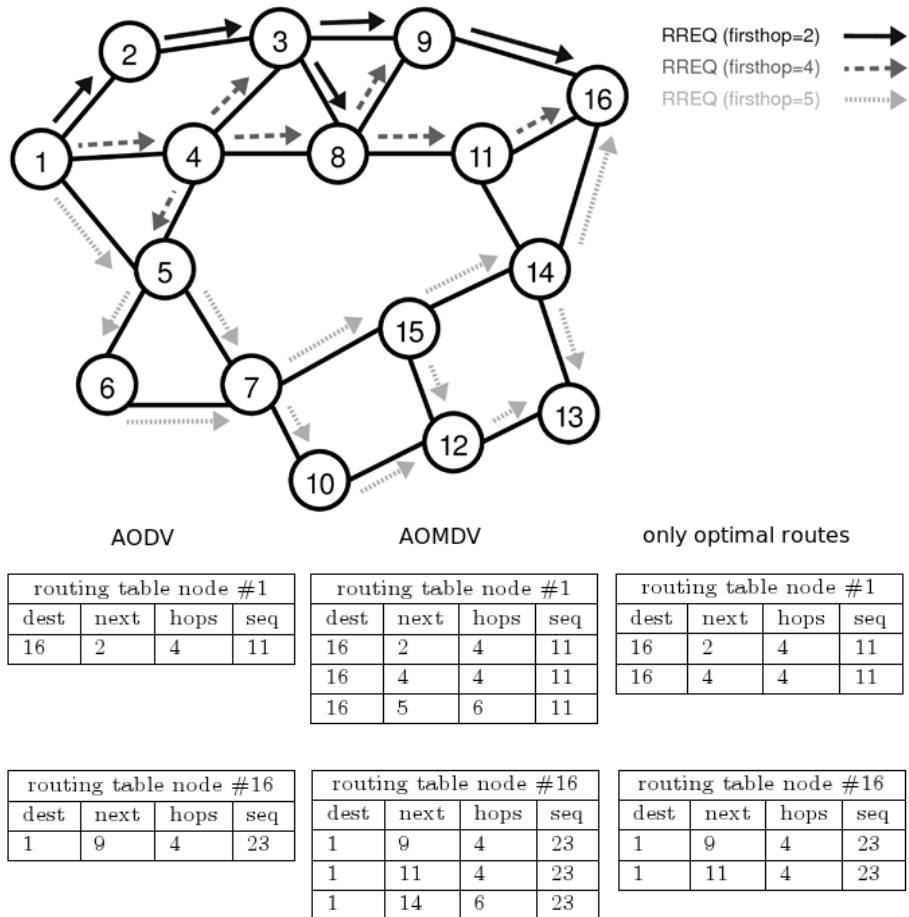
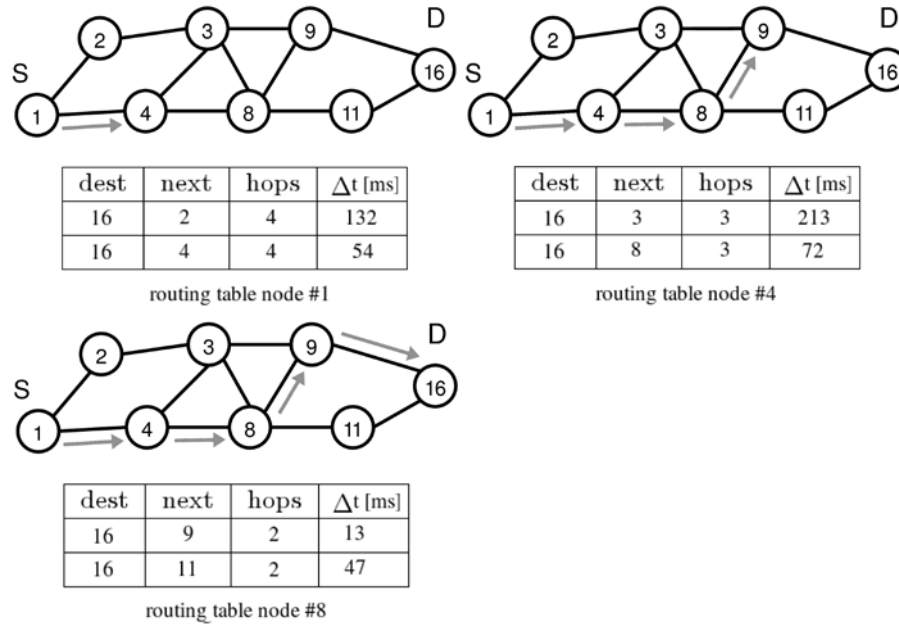

**Figure 5.** RREQ and different table update policies

As the source knows two paths towards node 16, it chooses the path according to the delay to the next-wake-up of the gateway node. In the left part of Figure 6, we can see that the time remaining to the next wake-up of node 2 is 132 ms, and the next wake-up of node 4 is in 54 ms. Therefore, the source node chooses to send the packet via node 4, because it can deliver the packet and empty its buffer earlier. The packet is routed in every intermediate node accordingly. Since we only added hop-count-optimal routes, packets are never routed away from the destination.

If we would apply WiseMAC with its simple periodic wake-up pattern, nodes would always forward over the same gateways, because the time shift between two node's wake-ups remains constant. With the moving wake-intervals MAC (Figure 4),

nodes will always choose their gateway according to the shortest delay to the next wake-up. The choice of the gateways may change, because the offset and minimum delays dynamically change with the moving intervals.



**Figure 6.** Packet forwarded from 1 to 16 choosing nodes with the soonest wake-up

## 4. Evaluation

### 4.1 Simulation Parameters and Scenarios

We performed our evaluation using the OMNeT++ network simulator [16] and the mobility framework [17]. The energy consumption model is based on the amount of energy that is used by the transceiver unit. We do not take processing costs of the CPU into account. Each node's energy consumption is calculated in respect to the time and input current that the node spends in the respective operation modes idle/receive, transmit and sleep. Furthermore, state transition delays are taken into account. The simulation parameters are summarized in Table 4. As the choice of the network topology may have an impact on the results, we considered the following three network topologies:

- uniformly distributed network topology of 90 nodes in an area of 300x300 m
- 7x7 nodes lattice square topology (Figure 7)
- 3x10 nodes grid topology (Figure 8)

We defined the lifetime of the network as the time until 10% of the nodes deplete or the network becomes partitioned. For each topology, we measured two different traffic patterns.

- Evenly distributed traffic: Every node starts reporting data according to the Poisson model with  $\lambda = 0.01$ . When every node generates the same amount of traffic, multi-path routing might not pay off, because the load is already balanced. As common single path routing protocols establish source-sink trees with some nodes having the burden to forward traffic of large sub-trees, multi-path routing still might help to redistribute the load over more hops.
- Neuralgic spots traffic: If there are neuralgic spots in the network that generate much traffic, whereas other parts stay more or less inactive, multi-path routing can pay off more. We assume that the three most distant nodes from the sink generate 20 times more traffic ( $\lambda = 0.05$ ) than all other nodes ( $\lambda = 0.0025$ ).

**Table 4.** Simulation Parameters

carrier frequency	868 MHz
bit rate	19.2 kbps
packet size including header	160 bits
transmitter power	0.1 mW
SNR threshold	4 dB
sensitivity	-101.2 dBm
sensitivity carrier sensing	-112 dBm
communication range	50 m
packet loss coefficient $\alpha$	3.5
carrier sensing range	100 m
node energy	20 J
supply voltage	3V
current	
transmit	12 mA
receive	4.5 mA
sleep	5 $\mu$ A
state transition delays	
receive to transmit	12 $\mu$ s
transmit to receive	12 $\mu$ s
sleep to receive	518 $\mu$ s
receive to sleep	10 $\mu$ s
transmit to sleep	10 $\mu$ s

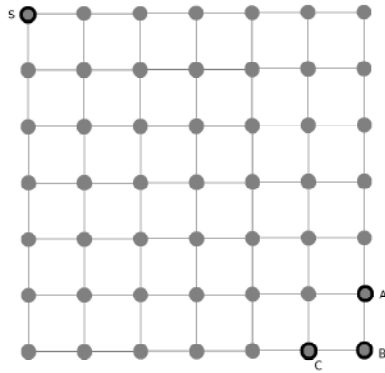

**Figure 7.** 7x7 nodes lattice square topology

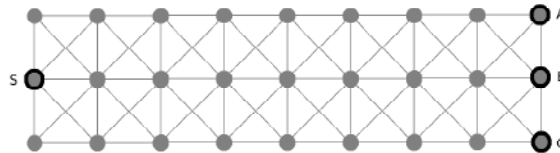

**Figure 8.** 3x10 nodes grid topology

#### 4.2 Lifetime and Delay Results

The results in Figure 9 and Figure 10 show an overall performance gain when applying the AOMDV-related scheme coupled with the next-soonest-wake-up routing paradigm of ~10-15% concerning network lifetime and one-way delay. When considering the low cost of some additional RREP messages in the initial route discovery phase, the results show that on-demand multi-path routing may provide limited but valuable contributions to extend network operability. In our simulation, the mechanism paid off when sticking to the hop count optimal routes only. The performance improvements are in a similar range as in [18] although the authors focused on wireless ad-hoc networks and on throughput optimization.

The exploitation of the MAC layer information about the next-soonest wake-up of the neighboring nodes paid off in respect to the one-way delay. This might be in conflict with the layered design paradigm, but in wireless sensor networks with scarce energy resources, such cross-layer approaches are acceptable, if higher efficiency can be achieved. Neither the different traffic patterns nor the topology has a big impact on the results.

In a second series of experiments, we performed all the experiments with another lifetime metric. In that case, we measured the first node depletion. The results differed only slightly from the results using the first lifetime metric. The overall gain also reached 10-15% in respect to lifetime and to one-way delay for all topologies and both traffic patterns.

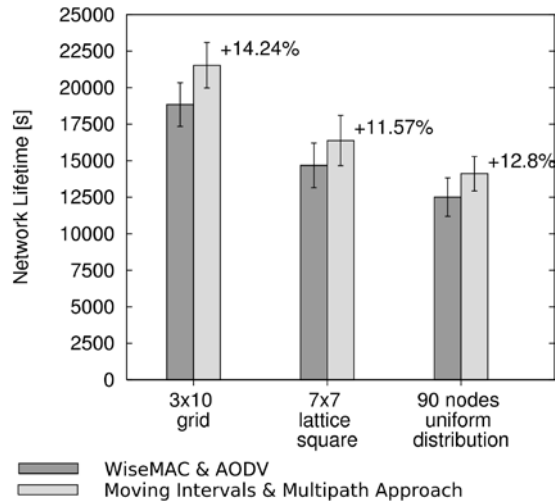

**Figure 9.** Network Lifetime

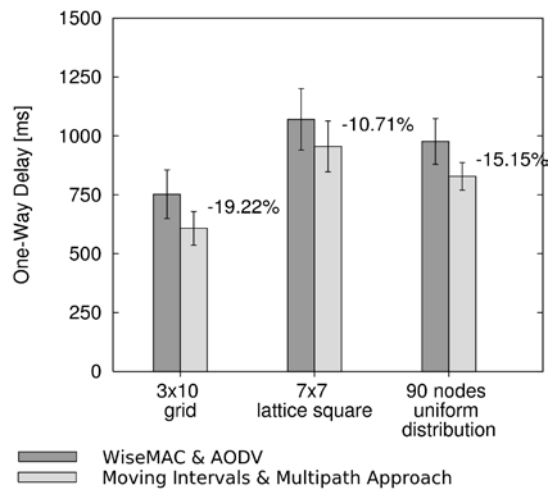

**Figure 10.** One-Way Delay

## 5. Conclusions

The paper proposed to integrate a multi-path routing protocol and appropriate MAC protocols with periodic wake-up to balance load in a wireless sensor network and achieve higher network lifetime. The proposed concept achieves this by exploiting cross-layer optimizations between MAC and routing protocol as well as by altering path update policies. The evaluation showed that the potential to achieve higher network lifetimes is limited when applying preamble sampling low-power MAC

protocols such as WiseMAC. WiseMAC amplifies the performance degrading route coupling effect, because it increases its carrier-sensing range with a more prohibitive carrier access policy. This increased the probability that transmissions along multiple paths interfere with each other. Load balancing of multipath-routing was deteriorated by the additional cost of coping with path interference. The mechanism exhibited performance gains of 10-15% in respect to throughput and average end-to-end delay.

## 6. References

- [1] El-Hoiydi, A.; Decotignie, J.-D.: WiseMAC: An Ultra Low Power MAC Protocol for Multihop Wireless Sensor Networks, ALGOSENSORS, 2004
- [2] Tsai, J; Moors, T.: A Review of Multipath Routing Protocols: From Wireless Ad Hoc to Mesh Networks, ACoRN Early Career Researcher Workshop on Wireless Multihop Networking, 2006
- [3] Perkins, C.E., M. Belding-Royer E.: Ad hoc On-Demand Distance Vector (AODV) Routing, RFC 3561, 2003
- [4] Johnson D.B.: Routing in Ad Hoc Networks of Mobile Hosts, Workshop on Mobile Computing Systems and Applications, IEEE Computer Society, 1994.
- [5] Dulman S., Nieberg T., Wu J., Havinga P.: Trade-off between Traffic Overhead and Reliability in Multi-path Routing for Wireless Sensor Networks, WCNC Workshop, 2003
- [6] Mueller, S., Ghosal D.: Multi-path Routing in Mobile Ad Hoc Networks: Issues and Challenges, MASCOTS Tutorials, 2003
- [7] Pearlman M. R., Haas Z. J., Sholander P., Tabrizi S. S.: On the impact of alternate path routing for load balancing in mobile ad hoc networks, ACM international symposium on Mobile ad hoc networking & computing. Boston, 2000
- [8] Voigt Th., Dunkels A., Braun, T.: On-demand Construction of Non-interfering Multiple Paths in Wireless Sensor Networks 2nd Workshop on Sensor Networks, Informatik 2005
- [9] Waharte, S., Boutaba, R.: Totally Disjoint Multi-path Routing in Multihop Wireless Networks, IEEE International Conference on Communications, 2006
- [10] Ganjali, Y., Keshavarzian, A.: Load Balancing in Ad hoc Networks: Single-path Routing vs. Multi-path Routing, IEEE Infocom, 2004
- [11] Ganesan D., Govindan R., Shenker S., Estrin D: Highly Resilient, Energy-Efficient Multi-path Routing in Wireless Sensor Networks, Mobile Computing and Communications Review, 2001
- [12] Lee, S.-J., Gerla, M.: Split Multi-path Routing with Maximally Disjoint Paths in Ad Hoc Networks, IEEE International Conference on Communications, 2001
- [13] Marina, M. K., Das S. R.: On Demand Multi-path Distance Vector Routing in Ad hoc Networks, IEEE International Conference on Network Protocols, 2001
- [14] Ye, Z, Krishnamurthy S.V., Tripathi S.K.: A Framework for Reliable Routing in Mobile Ad Hoc Networks, IEEE Infocom, 2003
- [15] Shah R. C., Rabaey J.: Energy Aware Routing for Low Energy Ad Hoc Sensor Networks, IEEE Wireless Communications and Networking Conference WCNC, 2002
- [16] Varga, A. : The OMNeT++ Discrete Event Simulation System, <http://www.omnetpp.org>, European Simulation Multiconference (ESM'2001), Prague, Czech Republic, June 2001
- [17] Mobility Framework for OMNeT++, <http://mobility-fw.sourceforge.net>
- [18] Bononi, L.; Di Felice, M.: Performance Analysis of Cross-Layered Multipath Routing and MAC Layer Solutions for Multi-hop Ad Hoc Networks, ACM MobiWAC 2006
- [19] Hurni, P.; Braun, T.: Improving Unsynchronized MAC Mechanisms in Wireless Sensor Networks, 1<sup>st</sup> ERCIM Workshop on eMobility, Coimbra, Portugal , May 21, 2007